



Seismic characteristic of underground stations

M. R. Esmaili¹, E. Hamilton^{2,*}

¹Faculty of engineering, Islamic Azad University, South Tehran Branch, Tehran Iran

²School of Civil engineering, University Sains Malaysia, Penang, Malaysia

ARTICLE INFO

Article history:

Received 25 November 2013

Received in revised form

20 January 2014

Accepted 22 January 2014

Keywords:

Seismic Loading

Underground structures

Earthquake

ABSTRACT

The aim of this paper is to introduce loads and their magnitude according to standards, research papers and empirical research or experience recommendations. Earthquake effects on underground structures have been investigated by researchers for many years because, in addition to the parameters in earthquake like aboveground structures, response behavior of buried structures during an earthquake is very complex. Acceleration of the project, Structural performance, Soil-structure interaction, Ductility capacity and, etc., are discussed for designing underground structures. Research studies in this field have not been led into exact consequences. Uncertain nature of soil behavior has caused no similar codified and certain procedures for underground structures. Qualitative study on approximate seismic force techniques with the flexible method and introducing a simple solution procedure which is under theoretical obligations is one of the other objectives of this study.

© 2014 IASE Publisher All rights reserved.

1. Introduction

Base on the author's knowledge, there is not any codified loading provision about underground structures. Many researchers proposed different ideas in this area. The choosing proper loads decrease the construction cost and also enhance safety during service life.

Although the effects of earthquake forces on underground structures such as tunnels and metro station is less important than Above-ground structures, design control of these structures in the ground motion during an earthquake is inevitable. The increasing development of underground structures and enormous costs for their construction, their importance in the urban transport network and their treatments, all in almost a hundred-years durability, persuade designers to investigate their stability against the risks of earthquakes. Study on the design process of underground structures is the main objective of this paper, and also their earthquake vulnerability should be investigated.

2. Loads Definition

Initially, the basis and origin of load must be clear which at the further process, modeling, analysis and detail design should be done in details. Dead & Live load are two different kind of load, which is introduced by traditional Codes, normally; dead loads are included of infrastructure, weight of fillers, rail facilities, split walls and partitions, fixed equipment installations and the soil dead weight, and live load are involved extra load divisions of platforms, corridors, commercial areas, facilities, light street traffic, train traffic, soil pressure, load of ground level buildings; loads due to temperature, creep, strain, and finally earthquake load are existed (Code 2800, 2005; Eurocode, 1994).

It is essential to determine the type of soil pressure (ACTIVE, PASSIVE and ATREST) for applying soil lateral pressure.

2.1. Live Load

According to the applicable standards, the maximum load that might be imposed during construction and operation of structures defined. There is no absolute codified standard for these loads in specific projects such as Metro. Different countries suggested loads according to their technologies, Capacity of the trains, architectural considerations, site specifications, geotechnical and other parameters. To designing the Tehran stations'

* Corresponding author.

E-mail address: E.Hamilton@yahoo.com (E. Hamilton)

Metro Systra Consulting Engineers (2010) suggested 660 kg/m^2 , 750 kg/m^2 and 1500 kg/m^2 for Platform and ticket sales counter, commercial areas and Installation areas respectively.

The common procedures in this subway tunnels and metro stations, is the effect of the vehicle's axles on the elastic substrate (soil) which has been suggested 2000 kg/m^2 by systra consulting engineers (2010). But in terms of any impact caused by traffic, Impact ratio of 1.2 considered. But these effects are just for the thin soil over the tunnel.

Train Load is a function of the inner-city trains (LRT) brands. Therefore, the final load should be announced to Consulting Engineers by the employer

that includes operation load with striking effect, centrifugal loads and the effects of lateral fluctuations.

2.2. Lateral loads due to soil pressure

For the important projects, the actual pressure of the soil will be measured via precise instruments, and then the applicable coefficient and equation are moderated by experimental results. Soil pressure determines by the rate of deformation, which can be occurred in soil and/or structure. The magnitude of maximum lateral displacement to reach the active and/or passive form is shown in Table 1 and Fig. 1.

Table 1: required lateral displacement for soil activation in ACTIVE and PASSIVE mode

Soil types	$\Delta L_a/H$	$\Delta L_p/H$
loos sand	0.001-0.002	0.01
compact sand	0.001-0.005	0.005
soft clay	0.02	0.04
stiff clay	0.01	0.02

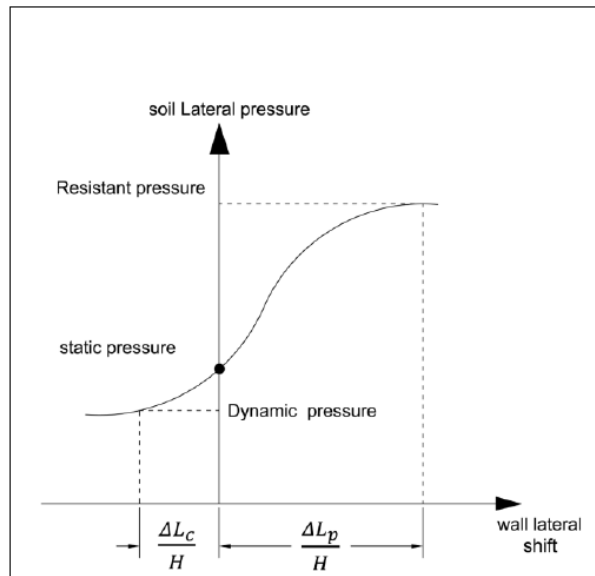

Fig. 1: Soil lateral displacement versus structure displacement

Due to the small movement that can convert pressure on the structure from Atrest mode to the Active mode, most of the researchers believe that the initial pressure which can be as much as Atrest, which can be modified and convert to the active pressure. If these mentioned structure has been associated with high rigidity, or a continues frame with almost high rigidity, such as stations and metro tunnels, the applied load by soil to structure cannot be more than Atrest, and since this force is higher than Active mode (Hashash et al., 2001). However, the work order can also be considerable.

It is necessary to know over time, and under the upper layers pressure effect and further consolidation, there likely achieve that lateral load reach to Atrest.

2.3. Load due to temperature changes

Because underground structures are not exposed to sunlight, they do not have so many temperature changes, and usually they do not carry considerable loads for a uniform temperature change over building design standards time, hence at least $10 \text{ }^\circ\text{C}$ is necessary to be consider for them, which is recommended to be apply on structures, once with a positive and once with a negative sign. Thermal gradient is the temperature difference of parts, which are partially buried recommended to be at least $7 \text{ }^\circ\text{C}$ (Eurocode, 1994).

2.4. Earthquake load

The underground structure is confined by the soil, so their deformations are limited and on the other hand, the high amount of the friction coefficient which absorbs the main part of the seismic energy reduced the effect of the ground motion on this motioned structure.

By releasing tensions on the rock layers, its energy spread in transverse and longitudinal direction. Under the effect of these waves, the horizontal and vertical accelerations are induced in the structure. It stresses and strains in structures due to this mentioned wave depend on the distance from the earthquake hypocenter, angle of collision of waves with structures, and different layers that are in their path.

The most important kind of these waves, is the shear wave which oscillates perpendicular to the propagation direction, and its impact almost considers in available analysis techniques (Grosse et al., 2003; Duke, 1969).

3. The influence of the soil conditions on the effective loads

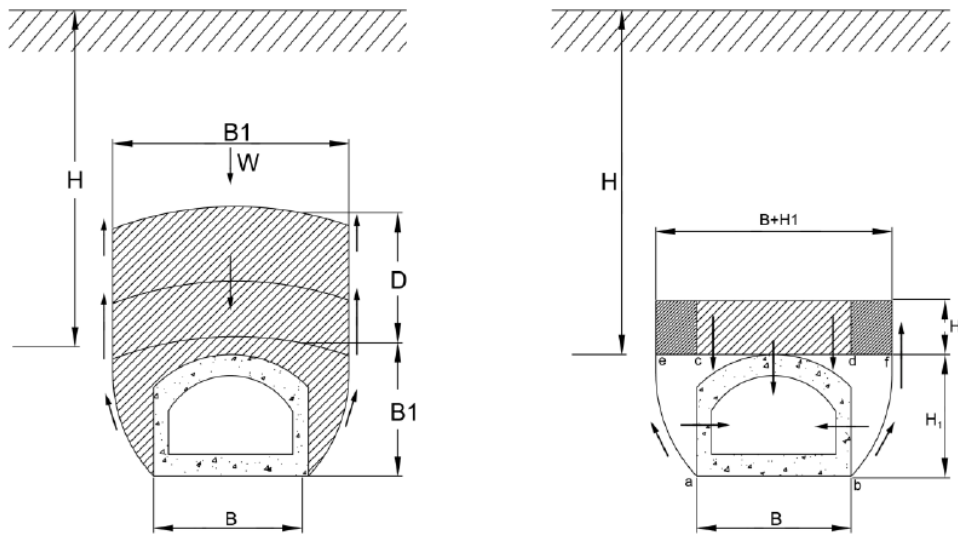

Fig. 2: Arc formation process in tunnel and its loads

3.2. Modeling

By experience and soil behavior measurement, some studies on the soil and structural system presented based on the stability of the underground structures and soil mass,

Suquet (1982); ESZTÓ (1952); Bierbaumer (1913); Terzaghi (1943) and, etc., presented some equations in 2D or 3D under dynamic and static loads.

The weights of the soil which are located above tunnels system are one of the most important loads. This load is equal to the soil weight, which has the tendency to fall after the tunnel construction. In practice due to the phenomenon of Arc Action, a large amount of overburden soil, transferred to soil walls at the both sides of the tunnel which is dependent on maintenance systems, geotechnical and tectonic profile of the soil. Soil pressure; impose plastic deformation to the tunnel section from all sides. In this case, if the maintenance system is not installed in the tunnel, this pressure will cause the tunnel convergence and will continue until the tunnel is completely blocked.

3.1. Arch formation phenomena in soils

The experience shows that load exerted on the temporary roof of the tunnel maintenance system or even the final tunnel lining is only a small percentage of the weight of soil above the tunnel. In this case, if the tunnel overburden's thickness becomes 1.5 times greater than the summation of width and height of the tunnel, load exerted on the maintenance system will be independent of the depth of the tunnel which is due to the arch action at the top of the tunnel (Fig. 2).

Earthquake loading are applied to the structure as a horizontal static force as a function of ground motion acceleration.

In the dynamic method, the soil and structure are analyzed under ground motion acceleration, which are induced to bedrock, but the dynamic analyzes is too time consuming compare to static analysis, and it is more sensitive to the mechanical property of the modeling component (UBC, 1997; Code 2800, 2005; Eurocode, 1994).

4. Earthquake effects on tunnels

It can be said that earthquake forces, do not determine the main dimension, of a buried structure,

since soil is too stiff in comparison with the buried structure, that its deformation do not cause major damage, but their sensitivity as specific structure, its considerable usage and longevity of these structures causes more attention to dynamic forces during its service life.

Effects of earthquake ground motion on underground structures classified into three general categories, Longitudinal bending, Compression Extension and Ovaling (Széchy, 1973).

Strain due to the structural longitudinal deformation and longitudinal bending, are usually analyzable based on the beam model on elastic substrate and considering the situation as equivalent linear or nonlinear spring.

4.1. Ductility or distortion methods

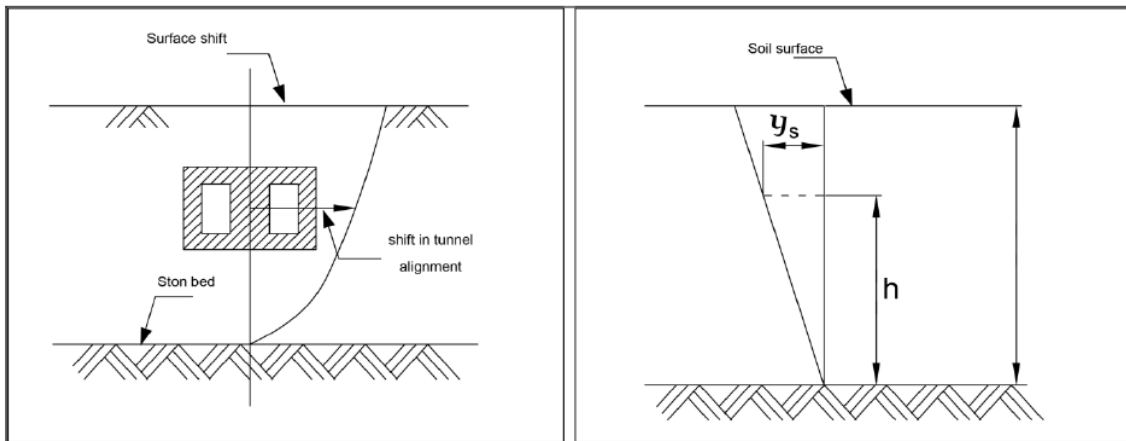

Fig. 3: deformation of underground structure regarding to its distance from bedrock ratio

4.2. Distortion calculation by latest methods

Regarding to the researches by Hashash et al. (2001), which is approved by United States Center for Advanced Infrastructure & Transportation, estimating the earthquake force base on ductility, rotation, the strain applied to the structure, moment due to this rotation and its design, are the aims of this method.

4.2.1. The dynamic pressure method

Knowing maximum ground acceleration, the quasi-static applied force to the structure is determined by the different method such as Mononobe Okabe methods, the dynamic pressure method which has the minimum number of parameters and less inaccuracy and results due to lack of strong theory for underground structures is the only criterion used for control design.

Methods based on flexibility, consider deformation caused by the earthquake (related to the geotechnical and soil mechanics), instead of direct calculation of the soil pressures or acceleration due to earthquake. This deformation mainly caused by shear wave of bedrock propagates due upward. How small soil diameter layer, the maximum acceleration will be more (Fig. 3).

It can be seen in the upper and lower sections of tunnels, and stations are under two different values of acceleration. As result, displacement of these points will be different. Totally any rotation in soil - structure system caused its nodes rotation. This theory is based on the method of providing flexibility in the structure node that Proposed by Professor KERISEL after investigation of TEHRAN's metro and suggested to apply frame rotation by 0.003 Rad at bedrock in depth of 100 m and linear deformation of acceleration.

4.3. Description of displacement interaction method

This method is suitable for rectangular and circular cross section and also is generalizable to other sections. The important is that this method needs the maximum acceleration of the earth in the construction a depth. But most of the standards (Code 2800, 2005) presented the maximum acceleration is given for bedrock.

4.3.1. Distortion of the circular tunnels at the displacement interaction method

Response of the tunnel is a function of compressibility and structural flexibility, in situ overhead pressure (γh) and in situ horizontal pressure coefficient of soil (K_0) (Fig. 4).

This method is accommodated to seismic loading by replacing free field shear stress to the in situ pressure, and coefficient of static pressure considered as (-1), to simulate the field simple shear mode. Then shear strain can be expressed as a function of shear stress.

With full sliding without detachment and no tangential shear force and diameter strain, the maximum axial force and bending moment can be stated.

$$T_{max} = \pm k_1 \frac{E_m}{(1+\nu_m)} r \gamma_{max} \quad (1)$$

$$M_{max} = \pm \frac{1}{6} k_1 \frac{E_m}{(1+\nu_m)} r^2 \gamma_{max} \quad (2)$$

$$k_1 = \frac{12(1-\nu_m)}{2F+5-6\nu_m} \quad (3)$$

Of course, in most of the tunnels, the Interface surface is located between the "full slide" and "no slip". Hence to determine the critical forces and critical deformation, both cases should be studied. Estimated maximum axial force for full slip is very low.

With reduction of compression coefficients and deformation, axial force due to earthquake increase ($\nu < 0.5$) and since the Poisson ratio tends to 0.5 (not drainage saturated clay), response to axial force would be independent of the compression because the soil considered to be incompressible.

The effect of the flexibility in the cover performance is presented by the normalized cover.

$$\frac{\Delta d_{ining}}{\Delta d_{free-field}} = \frac{2}{3} K_1 F \quad (4)$$

When the flexibility ratio (F) is less than 1 (Hard coating on soft ground), tunnel lining deformation is less than free field, and when (F) increases, lining deformation increase.

4.3.2. Rectangular tunnel distortion in the displacement interaction method

Shallow tunnels usually perform with box-shaped. These tunnels have different seismic behavior in comparison with circular tunnels. A box frame does not convey static loads as well as a circular cover, and walls and floors require greater thickness, and are more rigid, consequently, furthermore by potential of large ground deformation due to the low depth, interaction of soil - structure should be considered carefully. Seismic ground deformation in low depth due to their decreased hardness of side's soil, and also Site amplification effect, have the tendency to increase. As well, if the backfill characteristics are different with the field soil, seismic response would be different (Fig. 5).

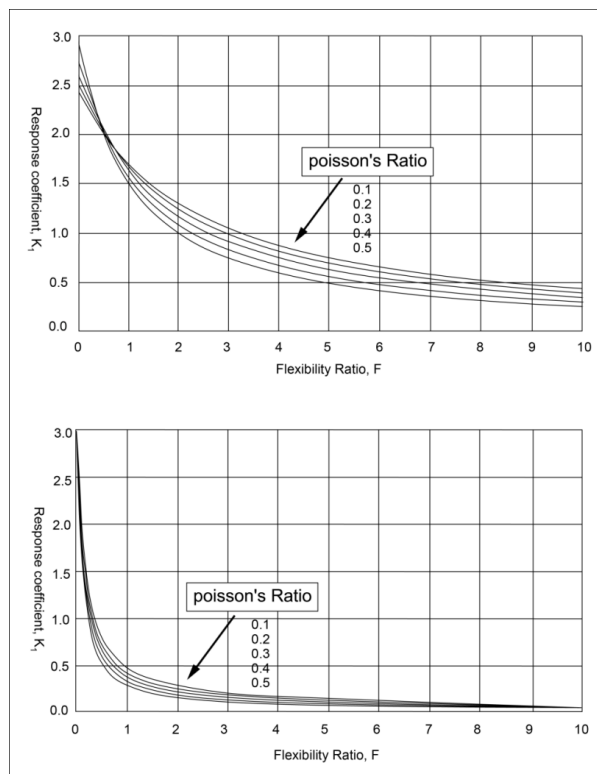

Fig. 4: coverage response factor versus flexibility ratio of full slip condition (circular tunnel)

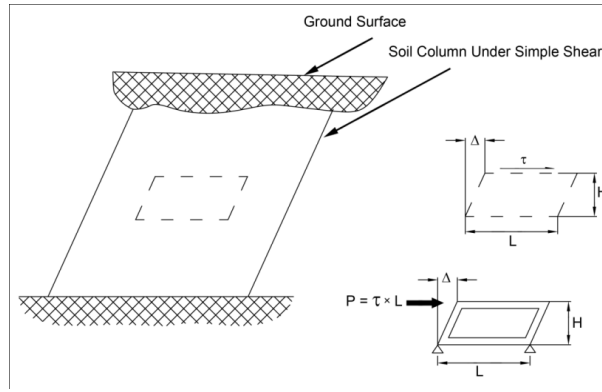

Fig. 5: Soil relative stiffness and a rectangular frame

$$\gamma_s = \frac{\Delta}{H} = \frac{e}{\sigma_m} \quad (5)$$

Flexibility ratio:

$$F = \frac{G_m W}{s_1 H} = \frac{G_m W}{s_1 H/w} \quad (6)$$

S_1 is the required force for deformation of structural units $S_1=1/\Delta$

G_m = shear stiffness

W = structure width

H = structure height

For the rectangular structure racking ratio, presents as, structure distortion to the distortion of the free field (Fig. 6).

$$R = \frac{\Delta_{structure}}{\Delta_{free-field}} = \frac{\left(\frac{\Delta_{structure}}{H}\right)}{\left(\frac{\Delta_{free-field}}{H}\right)} = \frac{\gamma_{structure}}{\gamma_{free-field}} \quad (7)$$

Wherein γ is equal to angular distortion, Δ is lateral racking deformation

If $F \rightarrow 0$ the structure is stiff.

If $F < 1$ then structure would be stiffer than the soil.

If $F = 1$ then soil and structure have same stiffness.

If $F > 1$ structure distortion is higher than free field.

If $F \rightarrow \infty$ then structure has no stiffness

Analyzes have shown that for a certain flexibility, normal distortion of a rectangular tunnel is approximately ten percent lower than the circular tunnel (Standard, 1977; Code 2800, 2005) (Fig. 7).

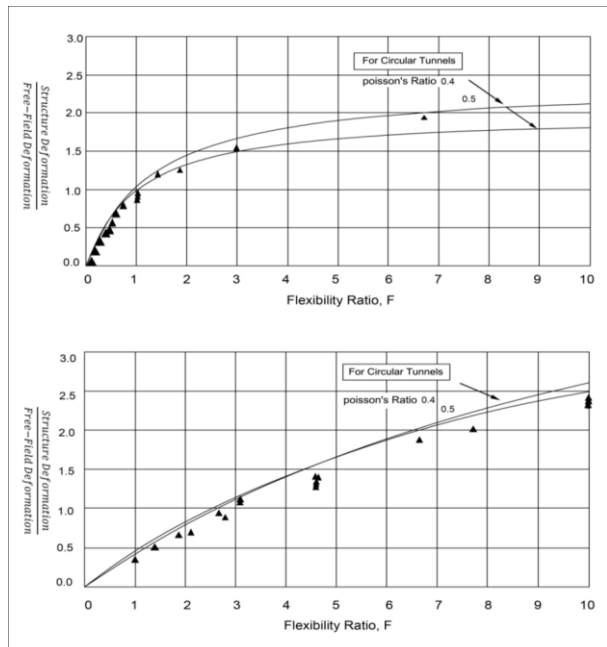

Fig. 6: Comparison of dimensionless structural deformation versus flexibility ratio of rectangular and circular

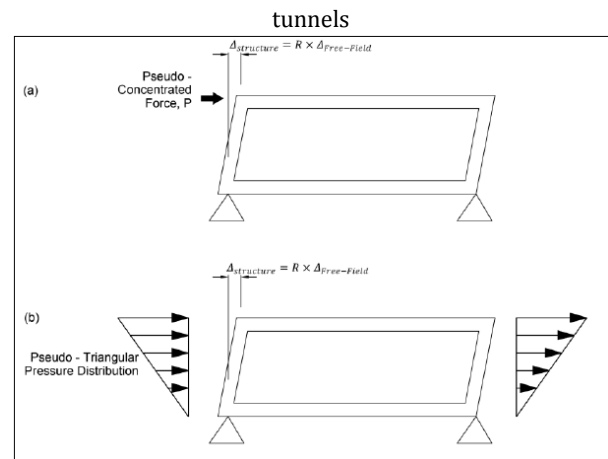

Fig. 7: Simplified frame model of tunnel (a) quasi-concentrated load for deep tunnel (b) quasi-triangular pressure for shallow tunnel

5. Conclusion

The source of dead and live loads and their magnitude carried out in accordance with standards and technical conclusion. Earthquake force and its loading do not consider being as a secondary result but due to the sensitivity and long life and inability to repair, these structures should have an acceptable safety factor. To determine the earthquake effect,

distortion should be obtained from ductility method, and flexibility for two earthquake levels. (Of both design and serviceability earthquake level), structure should be simulated by software; extra soil pressure should be calculated and applied to the tunnel. By modifying the springs employed for modeling stiffness up to their distortion, design moment and other important design parameters will be obtained.

References

- Bierbaumer A. (1913). Die Dimensionierung des Tunnelmauerwerkes. Studien von Ing. A. Bierbaumer, W. Engelmann.
- Code I.S. Standard 2800 (2005). Building and Housing Research Centre, Tehran, Iran.
- Duke CM (1969). Techniques for field measurement of shear wave velocity in soils.
- Eszto P (1952). Principle of Rock Movement. Acta technica, 4, 169.
- EureCode C (1994). 8: Design provisions for earthquake resistance of structures. Part, 2, 1998-2.
- Grosse CU, Reinhardt HW, Finck F (2003). Signal-based acoustic emission Techniques in civil engineering. Journal of materials in civil engineering, 15, 274-279.
- Hashash Y, Hook JJ, Schmidt B (2001). Seismic design and analysis of underground structures. Tunnelling and Underground Space Technology, 16, 247-293.
- Muller F, Keintzel E (1978). Approximate analysis of torsional effects in the new German Seismic Code DIN 4149. 101-108.
- Standard, A. (1971). 318-71,". Building Code Requirements for Reinforced Concrete (ACI 318-71), American Concrete Institute, Detroit, 78.
- Suquet P (1982). Plasticité et homogénéisation. Ph.D. thesis, Université Pierre et Marie Curie (Paris VI).
- Szechy K (1973). The art of tunnelling. Akademiai Kiado. Budapest, 2nd English edition, (SW/37), 1097.
- Systra Consulting Engineers (2010). <http://www.systraconsulting.com> [Available in 13.feb.2010]
- Terzaghi K. (1943). Theoretical soil mechanics.
- UBC (1997) . 'Uniform building Code, International Conference of Building Officials, Whittier, California.